

B (1:1)

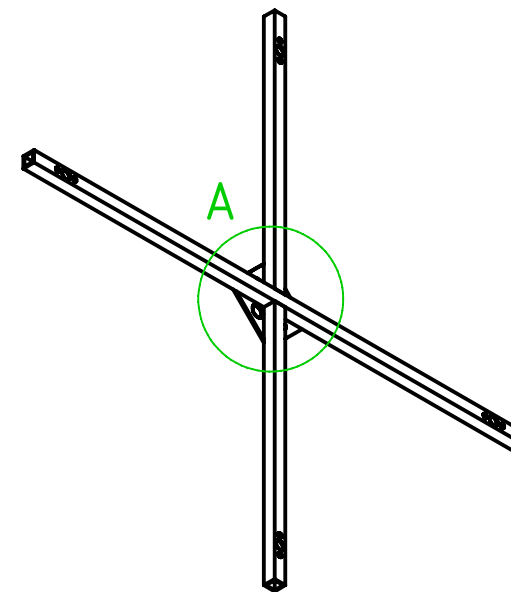

A (1:1)

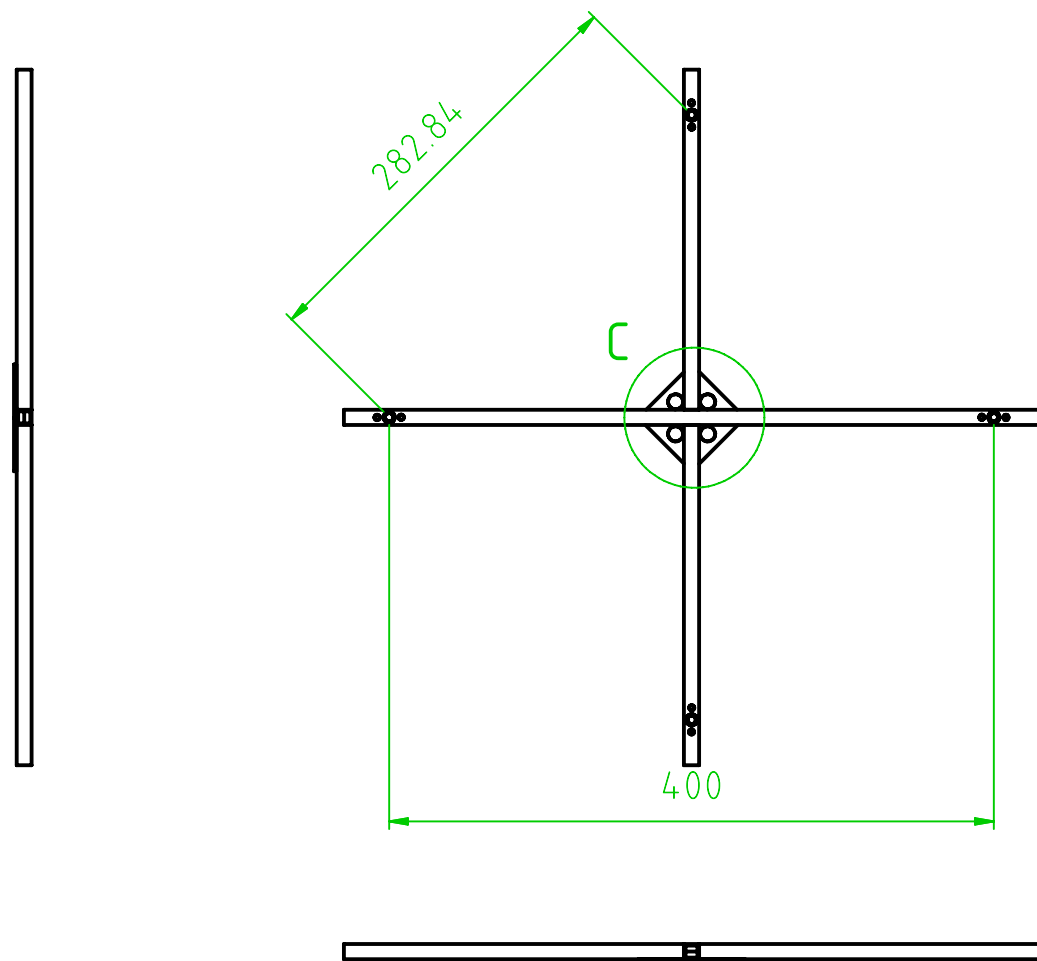
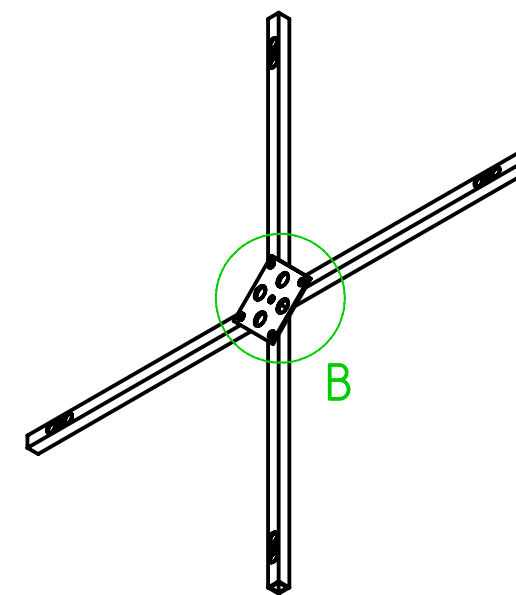
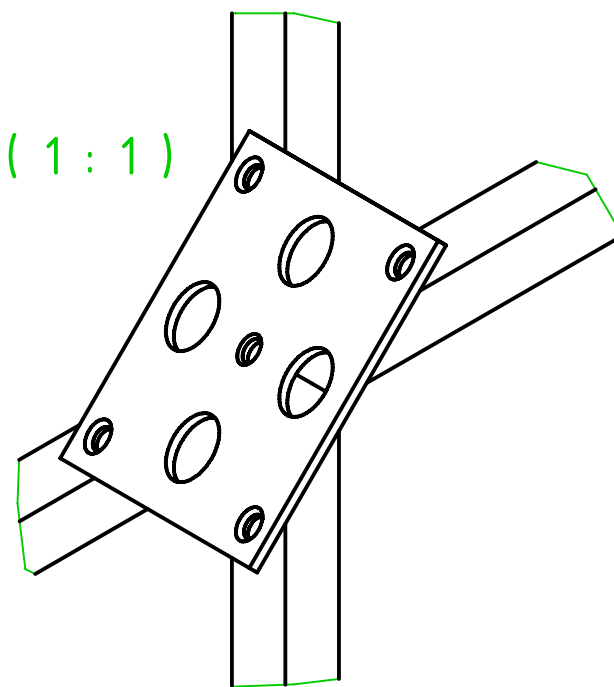
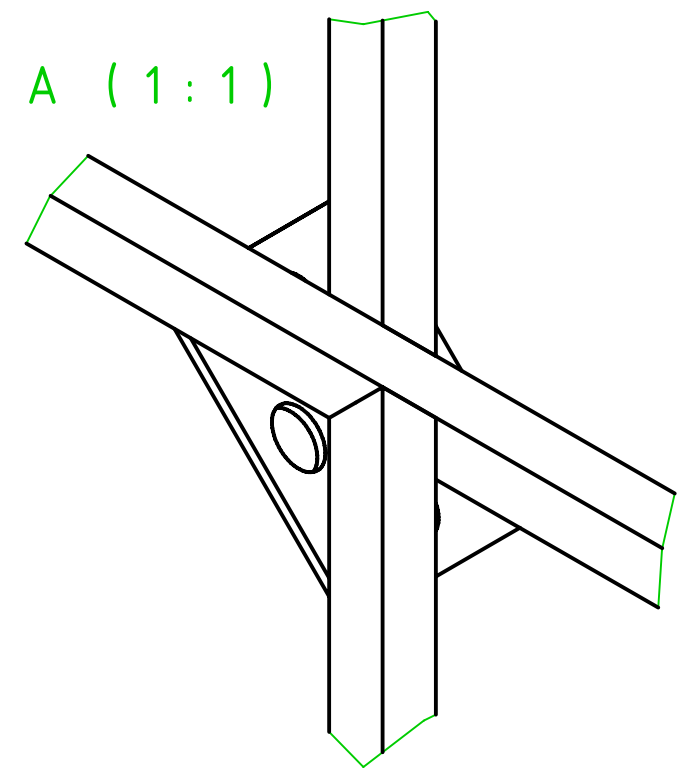

		Surface	Scale	Position	Quantity
			-	-	-
	Date	Name	www.speedyweb.at www.mikrokopter.de		
	Drawn 15.06.2007	Speedy			
	Checked				
	Standard				
Rahmen Zusammenbau					Page 3
State	Changes	Date	Name	Filename	Pg

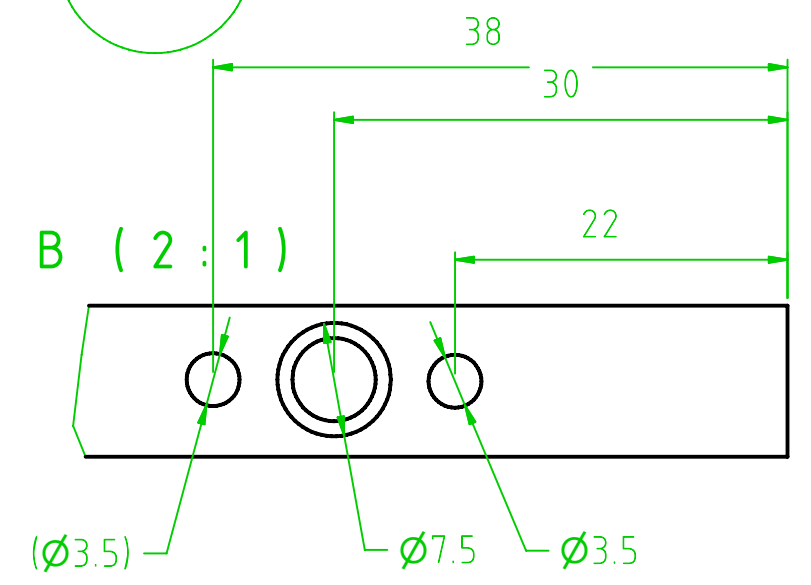
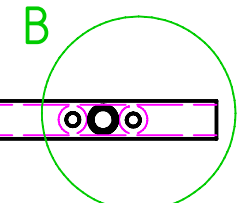
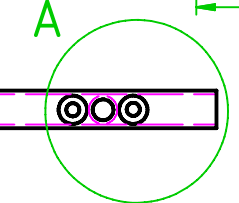
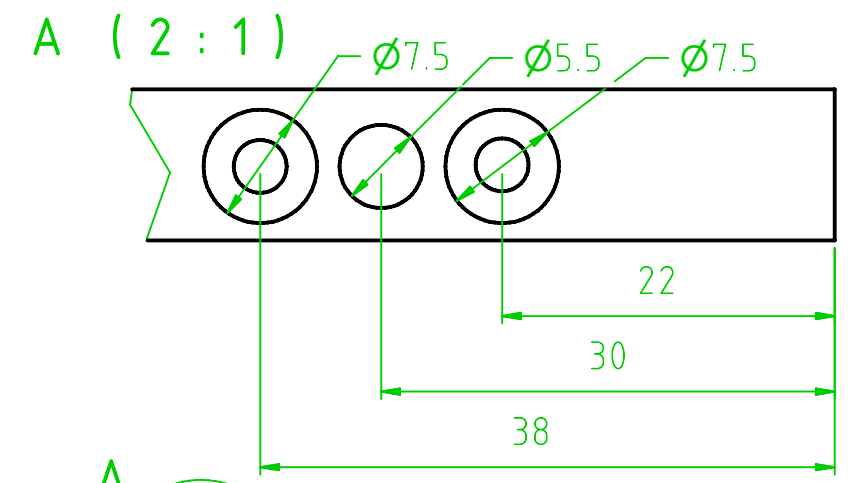
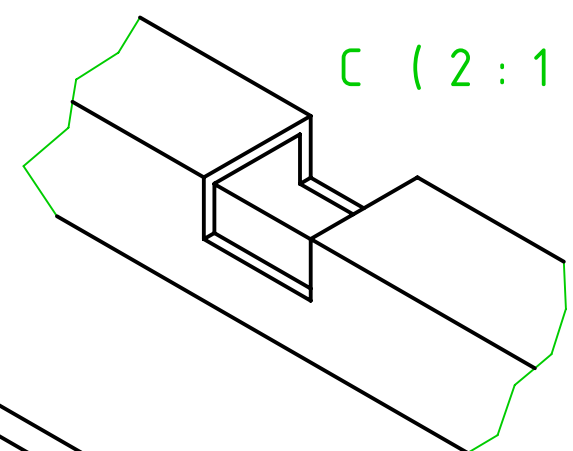
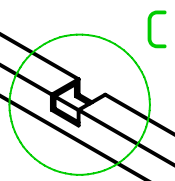
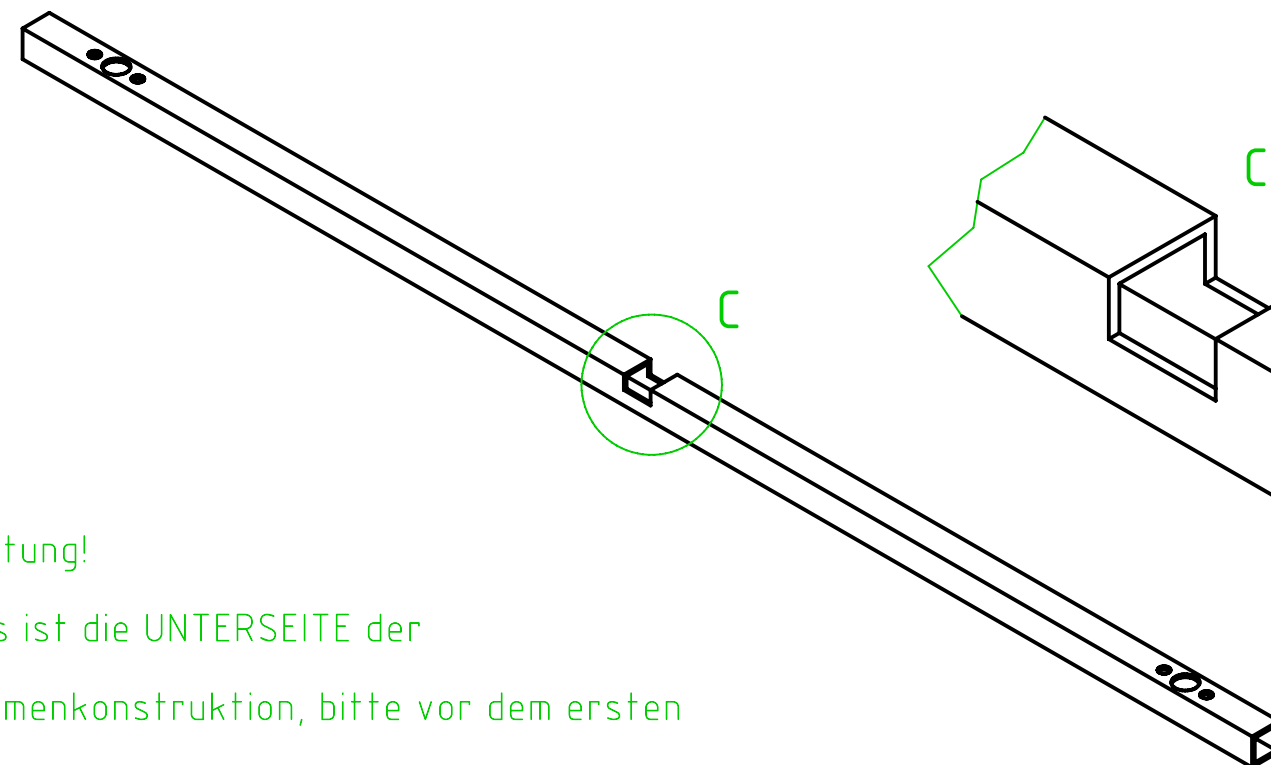
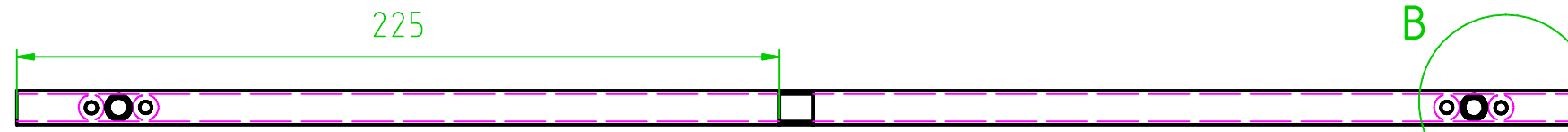
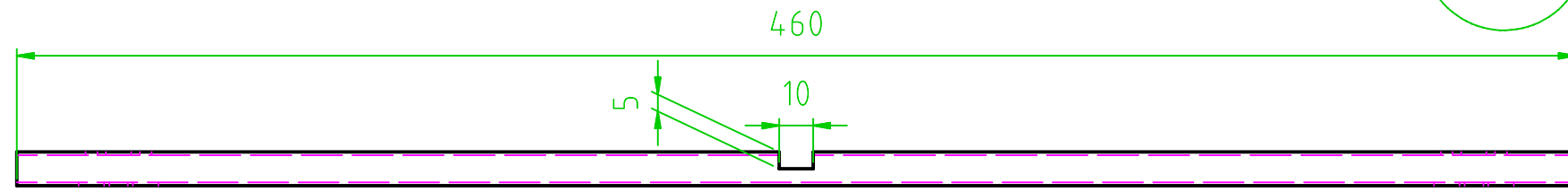
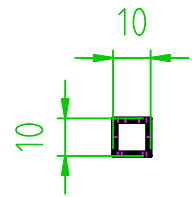
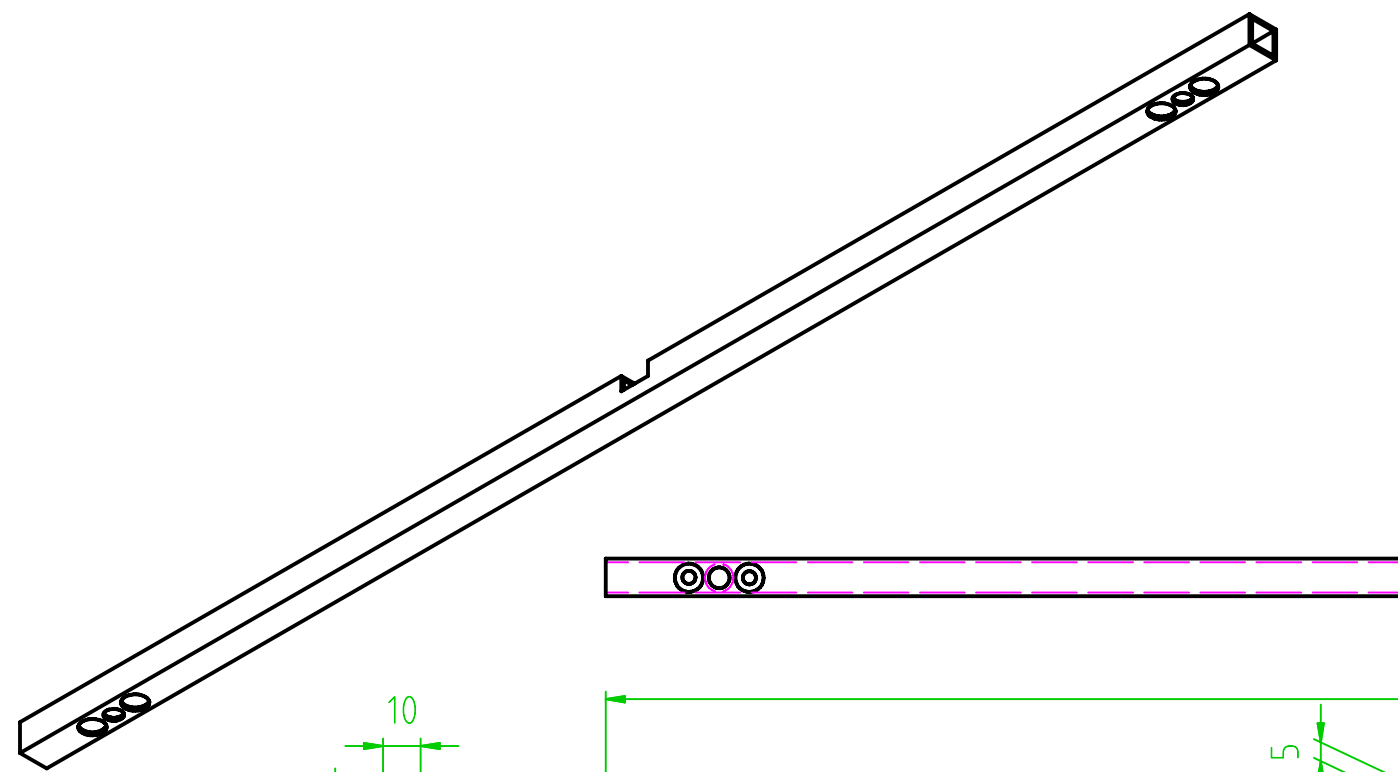

Achtung!

Dies ist die UNTERSEITE der Rahmenkonstruktion, bitte vor dem ersten bohren gleich Oberseite und Unterseite eindeutig markieren.

		Surface	Scale 1:2	Position -	Quantity -
			Aluminium	-	-
		Date	www.speedyweb.at		
		Drawn 15.06.2007	www.mikrokoetter.de		
		Checked			
		Standard			
			Mikrokoetter UNTEN		Page 1
					Pg
State	Changes	Date	Name	Filename	

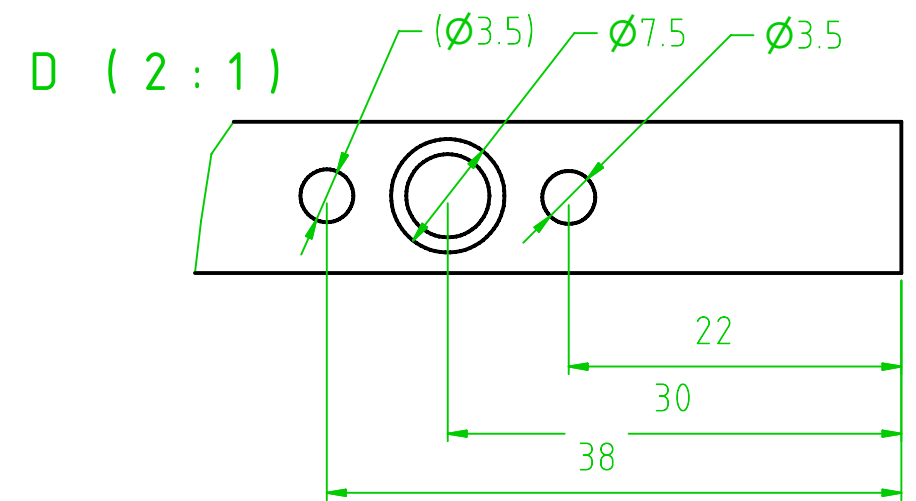
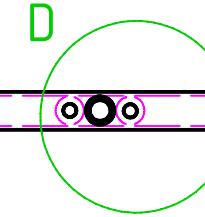
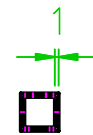
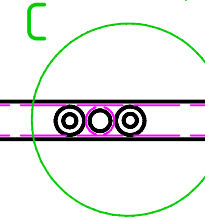
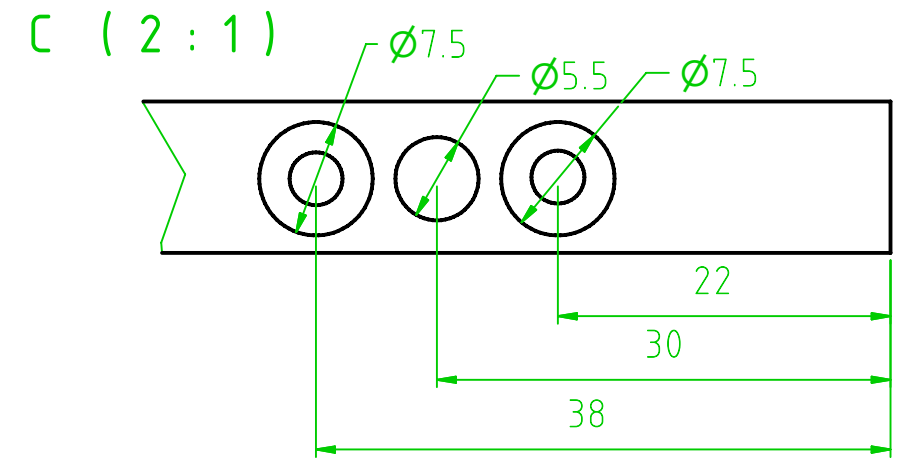
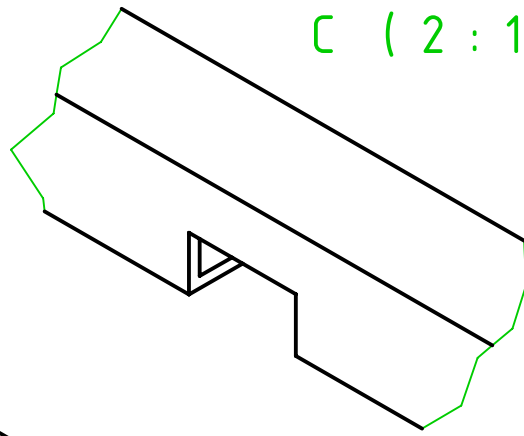
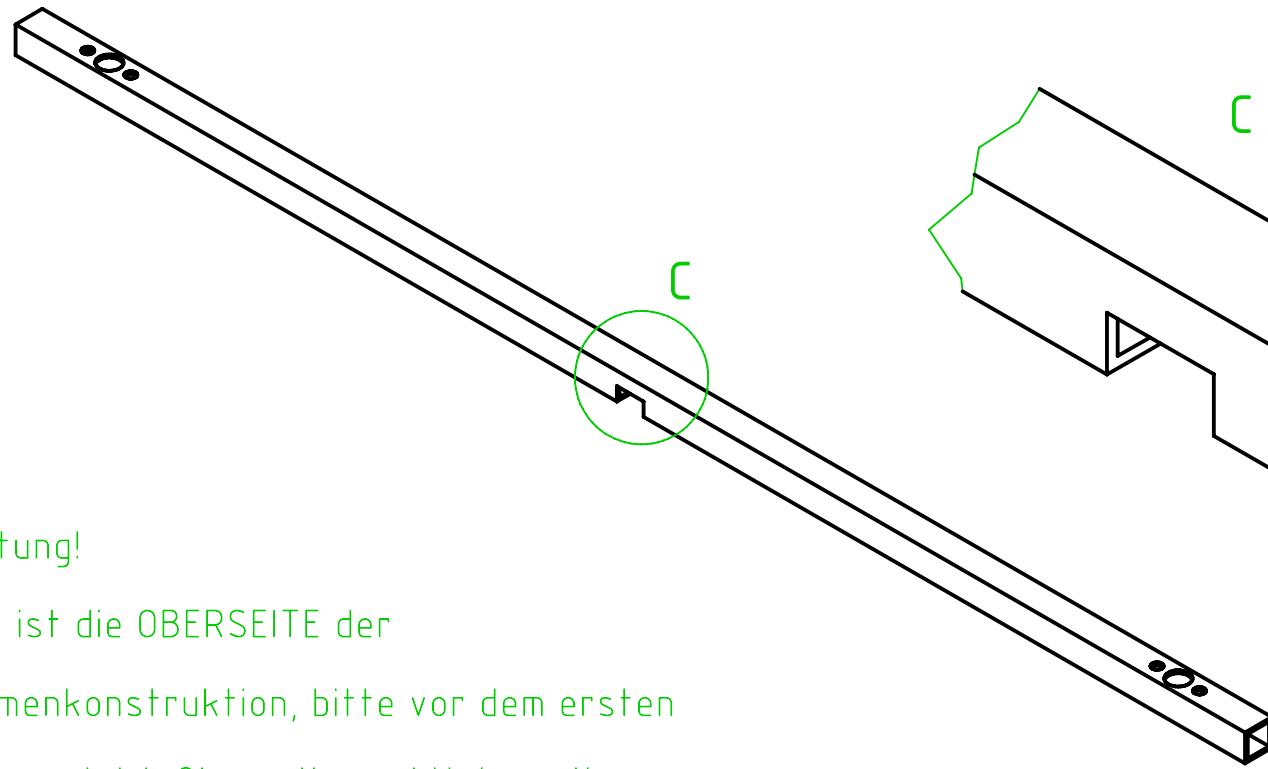
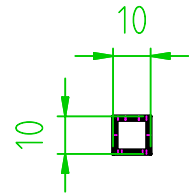
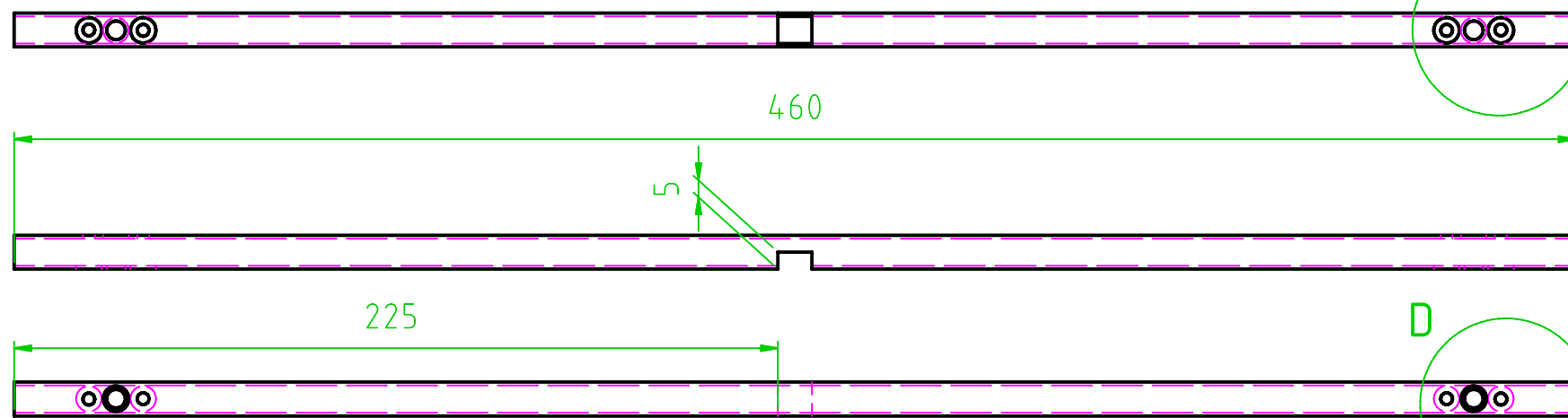
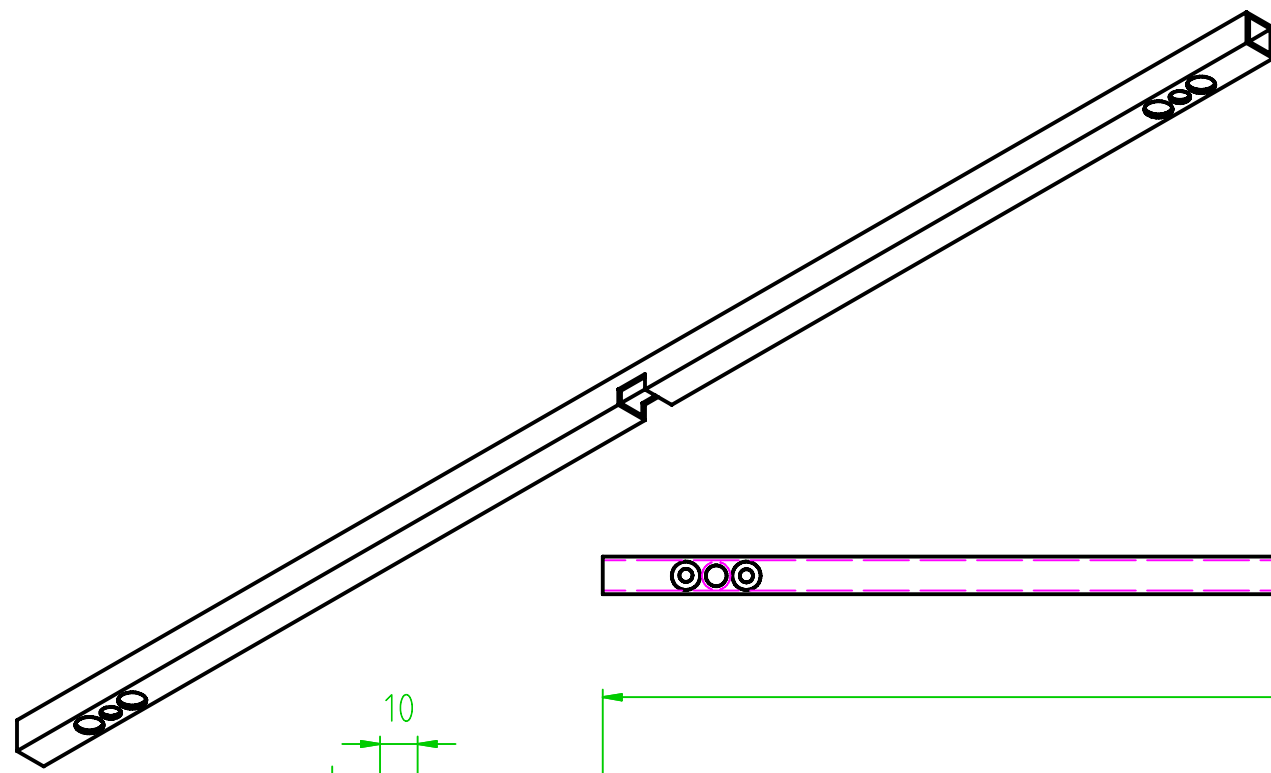

Achtung!
 Dies ist die OBERSEITE der
 Rahmenkonstruktion, bitte vor dem ersten
 bohren gleich Oberseite und Unterseite
 eindeutig markieren.

		Surface	Scale 1:2	Position -	Quantity -
			Aluminium	-	-
		Date	Name	www.speedyweb.at	
		Drawn 15.06.2007	Speedy	www.mikrokoetter.de	
		Checked			
		Standard			
			Mikrokoetter OBEN		Page 2
					Pg
State	Changes	Date	Name	Filename	

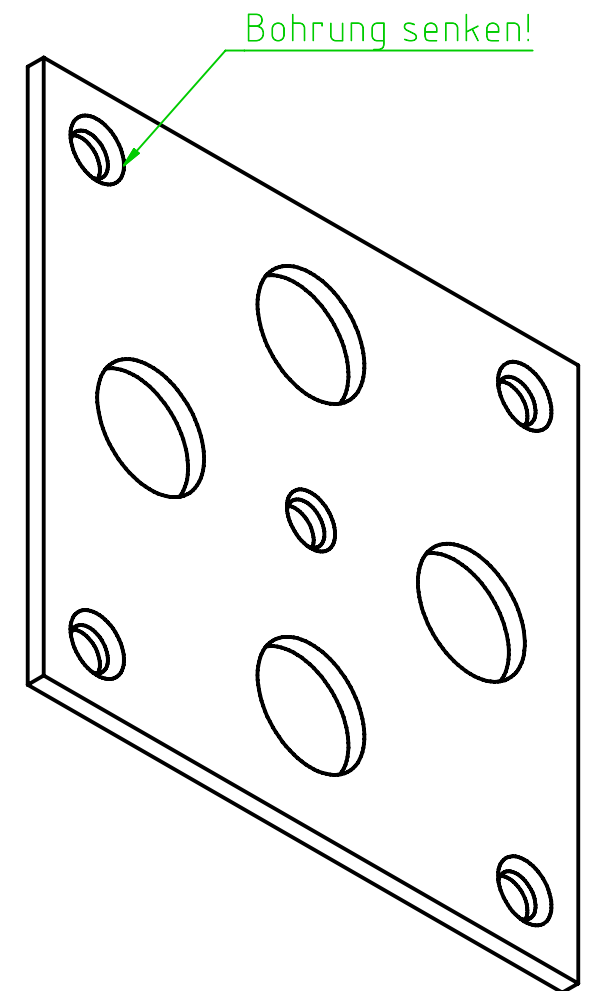
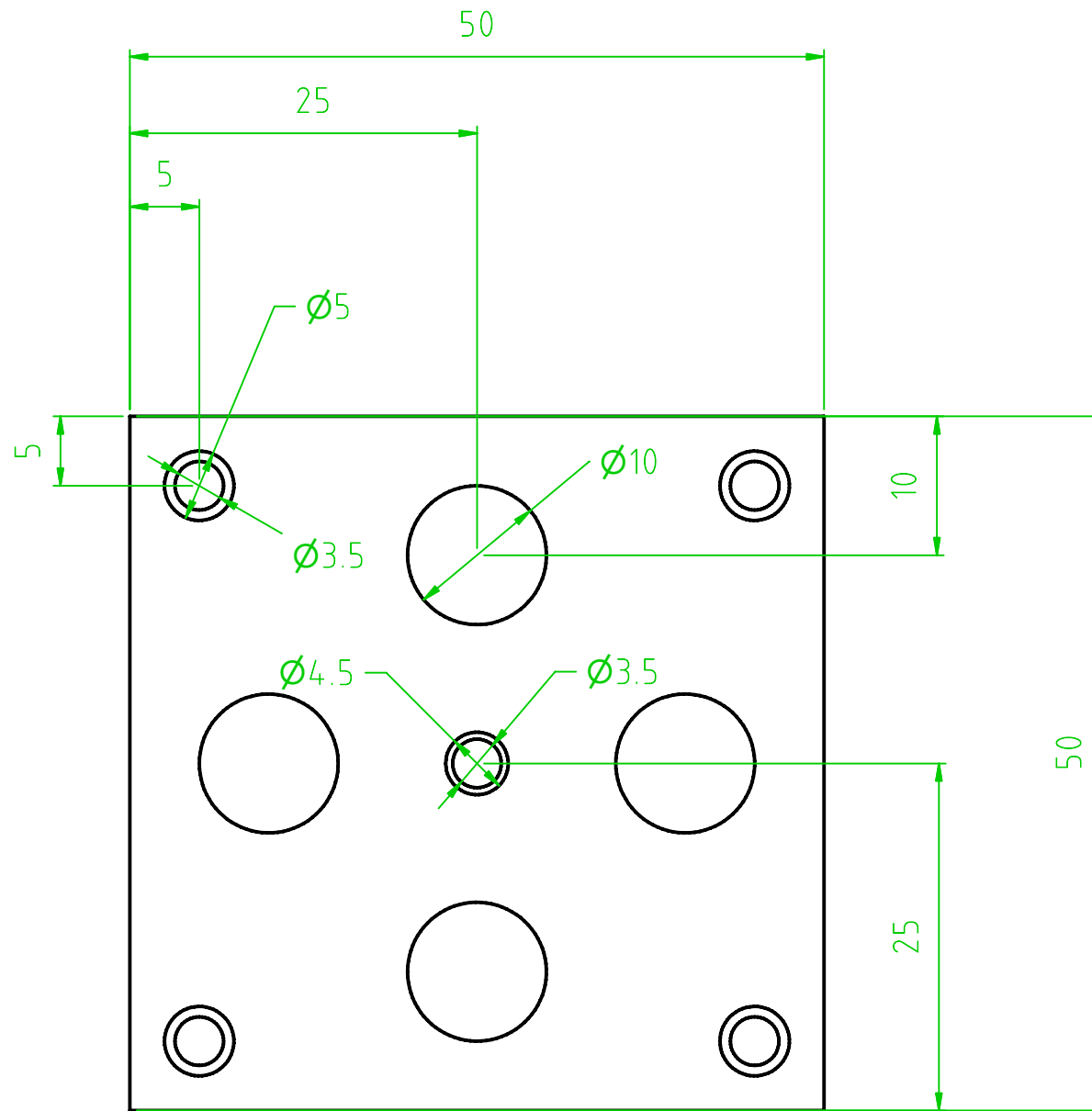
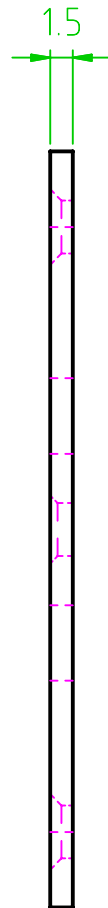
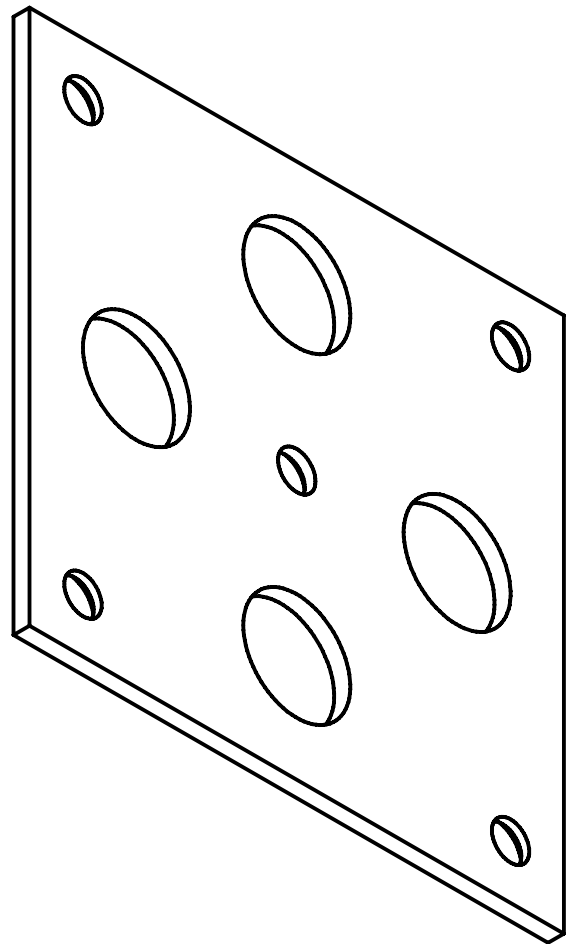

		Surface	Scale 1:2	Position -	Quantity -
			Aluminium	-	-
		Drawn	Date	Name	www.speedyweb.at www.mikrokoetter.de
		18.06.2007	Speedy		
		Checked			
		Standard			
					Page -
Stabilisierungsplatte					Pg
State	Changes	Date	Name	Filename	