

Surface		Scale	Position	Quantity
		-	-	-
		-	-	-
Drawn	Date	Name		
Checked	15.06.2007	Speedy		
Standard				
www.speedyweb.at				Page 3
www.mikrokoetter.de				
Rahmen Zusammenbau				Pg
State	Changes	Date	Name	Filename

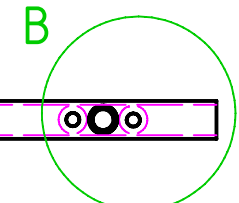

Achtung!
 Dies ist die UNTERSEITE der
 Rahmenkonstruktion, bitte vor dem ersten
 bohren gleich Oberseite und Unterseite
 eindeutig markieren.

		Surface	Scale 1:2	Position -	Quantity -
			Aluminium		
		Date	Name	www.speedyweb.at	
		Drawn 15.06.2007	Speedy	www.mikrokoetter.de	
		Checked			
		Standard			
				Mikrokoetter UNTEN	
				Page 1	Pg
State	Changes	Date	Name	Filename	

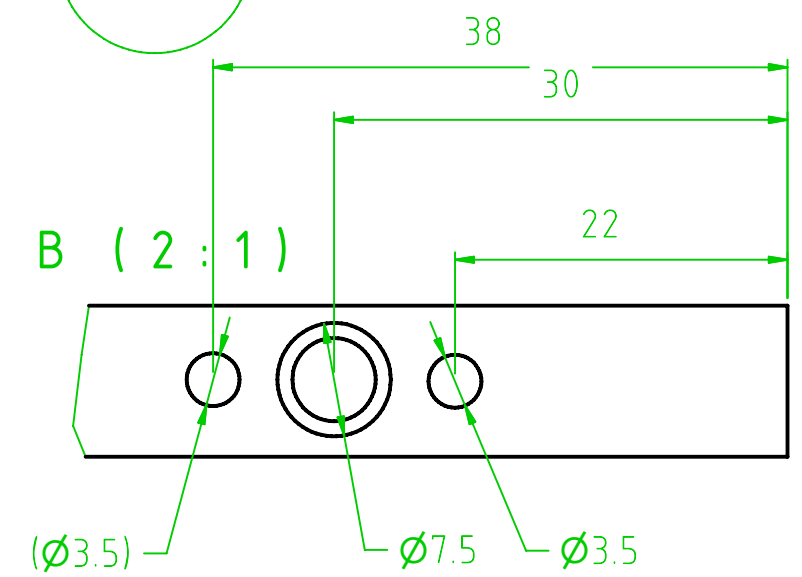
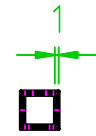
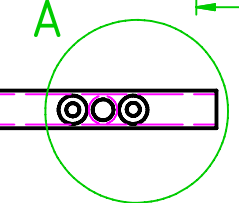
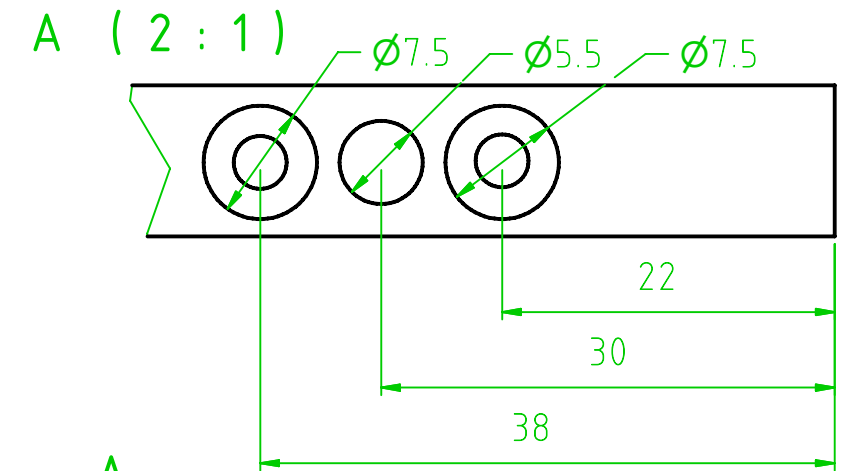
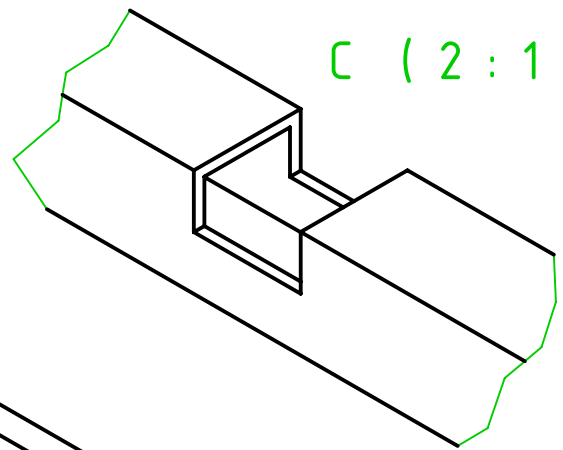
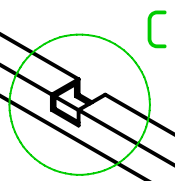
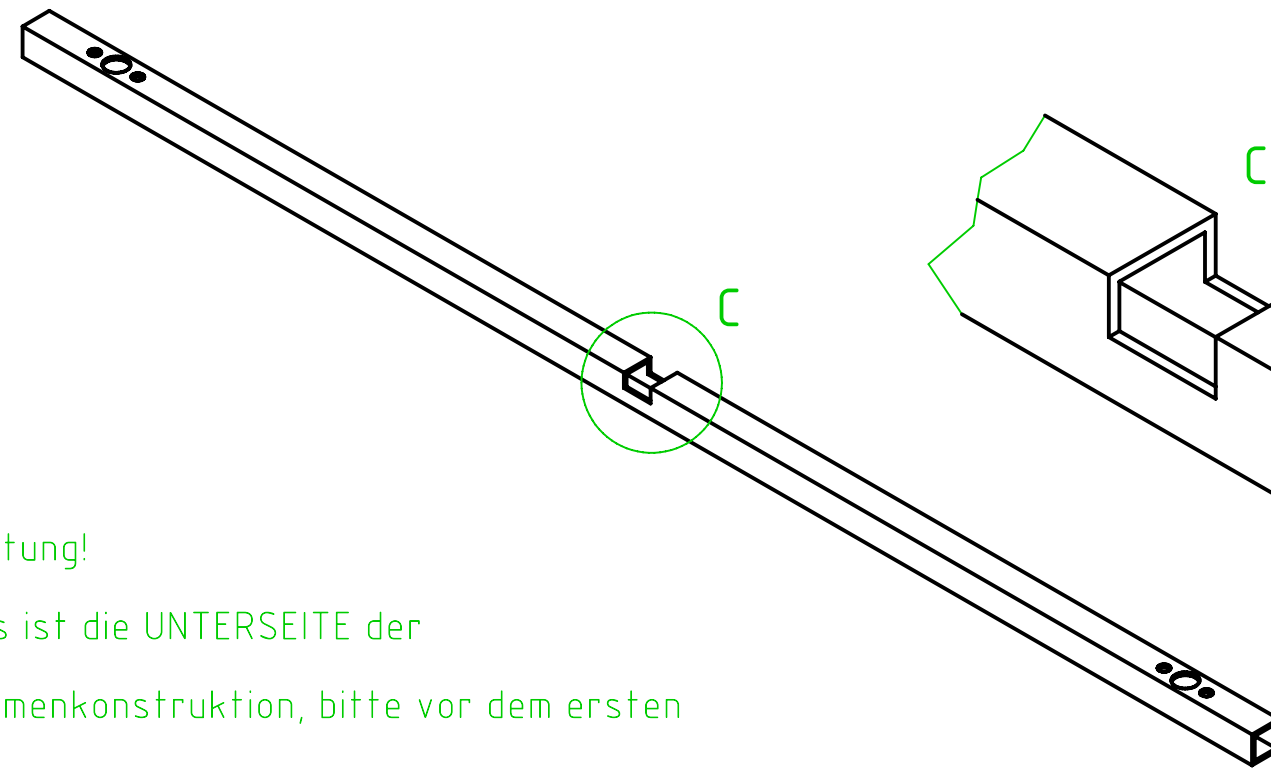
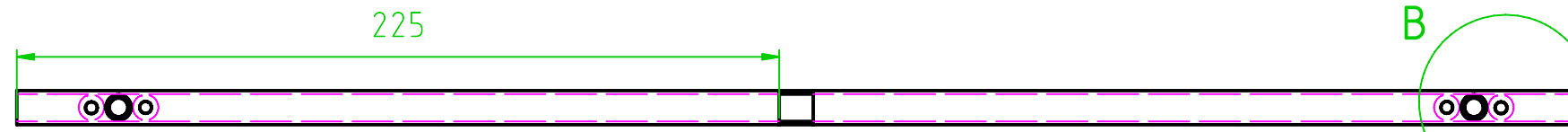
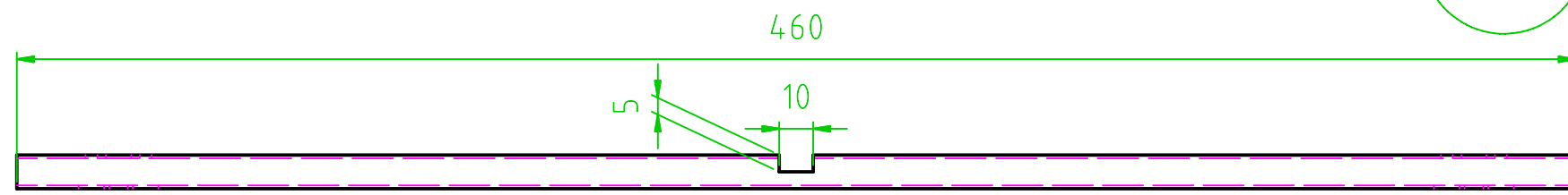
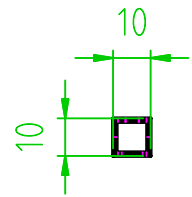
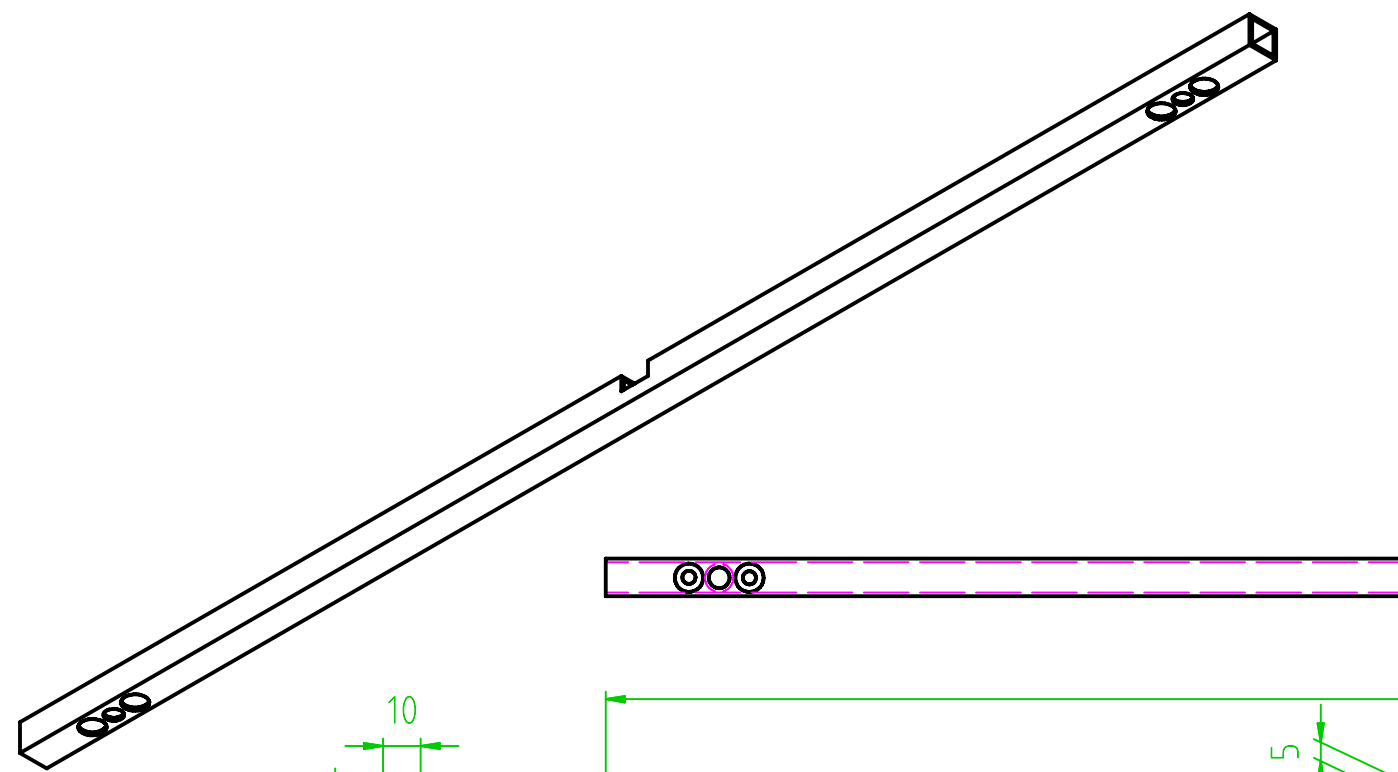
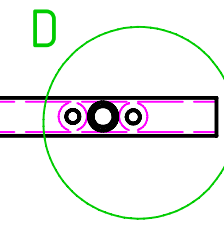
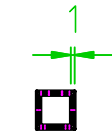
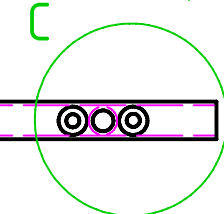
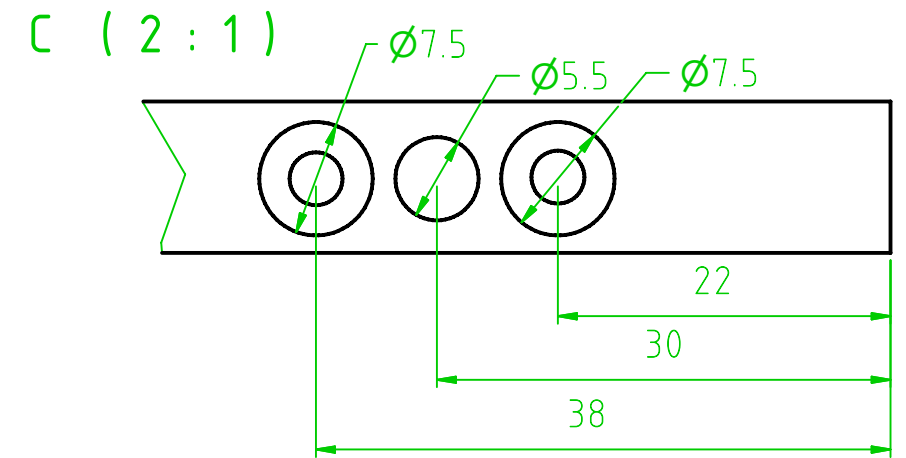
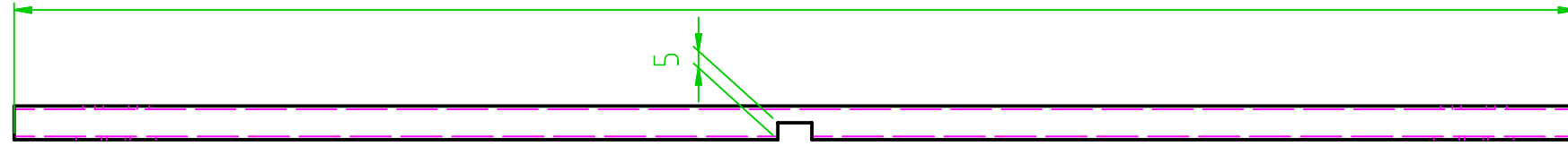
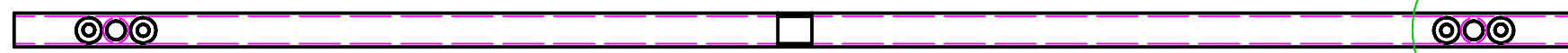
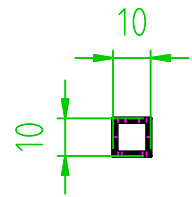
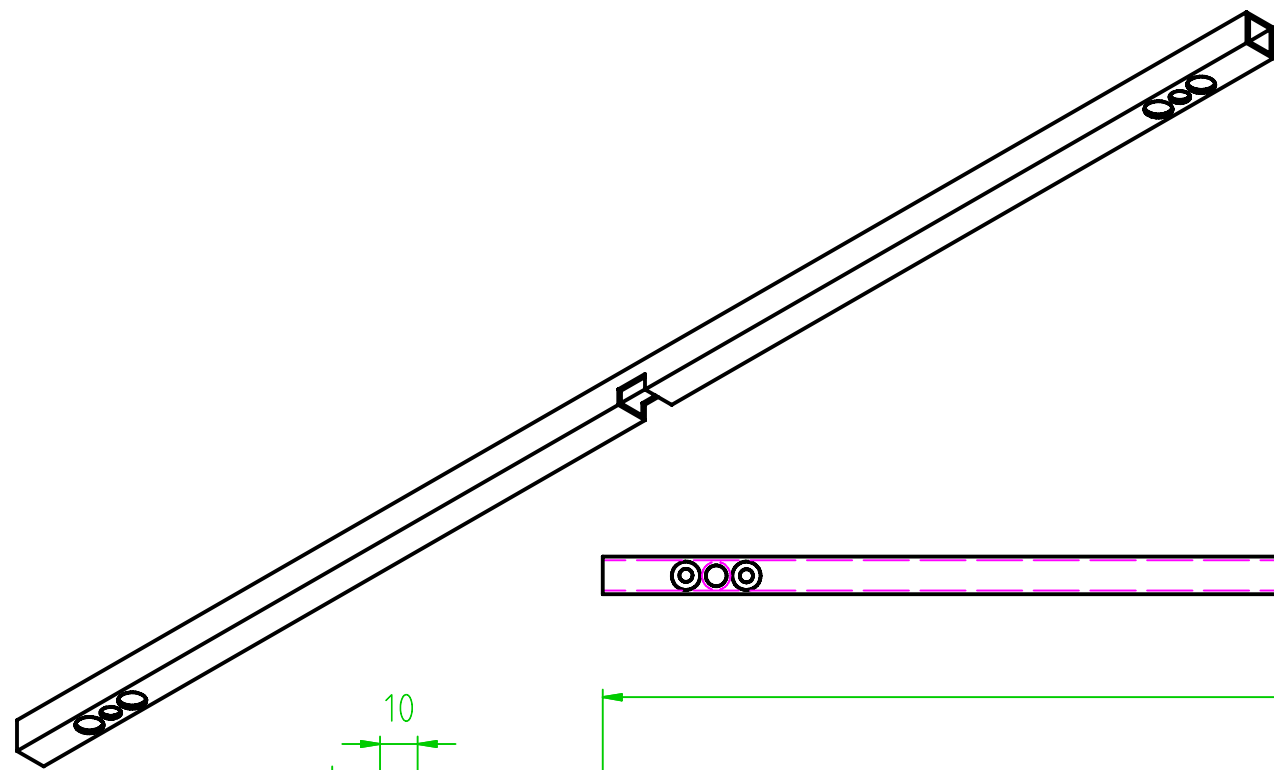

C (2:1)

D (2:1)

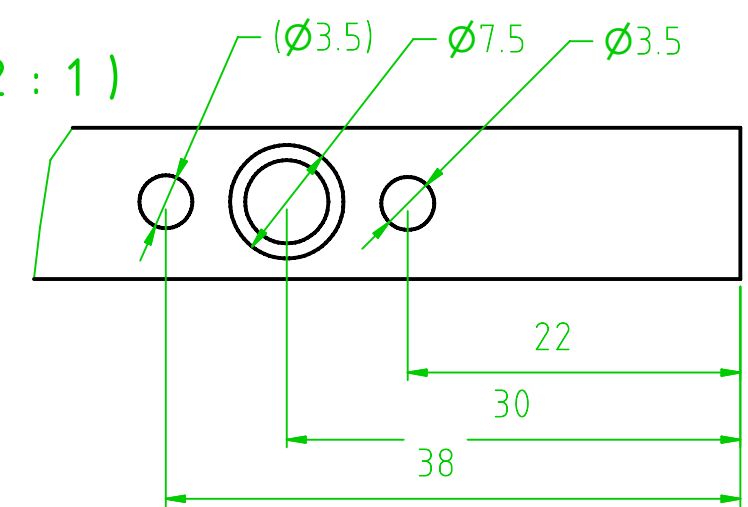

Achtung!
 Dies ist die OBERSEITE der
 Rahmenkonstruktion, bitte vor dem ersten
 bohren gleich Oberseite und Unterseite
 eindeutig markieren.

		Surface	Scale 1:2	Position -	Quantity -
			Aluminium		
		Date	Name	www.speedyweb.at	
		Drawn 15.06.2007	Speedy	www.mikrokoetter.de	
		Checked			
		Standard			
			Mikrokoetter OBEN		Page 2
					Pg
State	Changes	Date	Name	Filename	

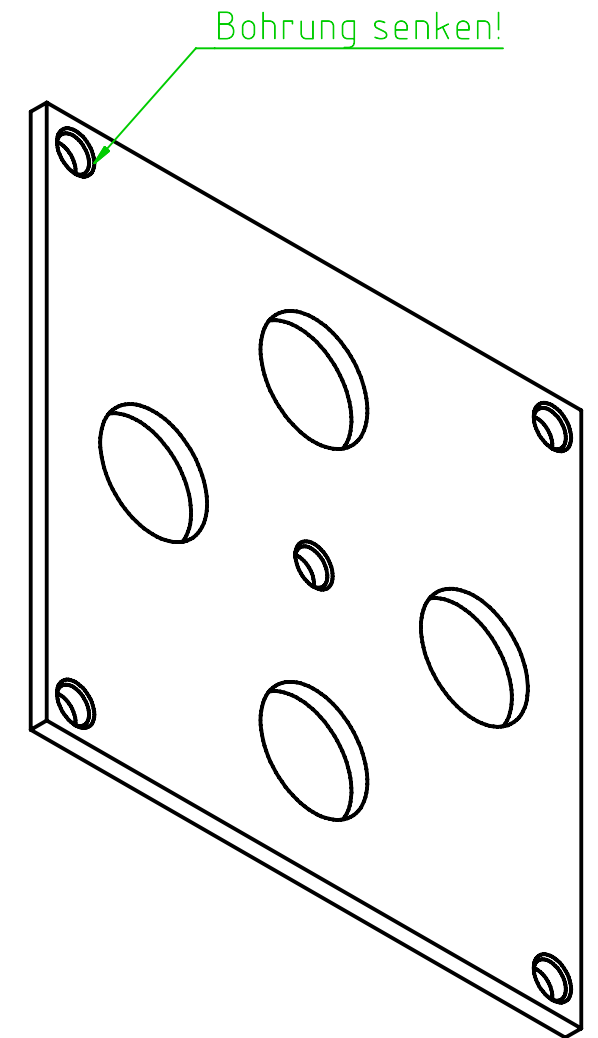
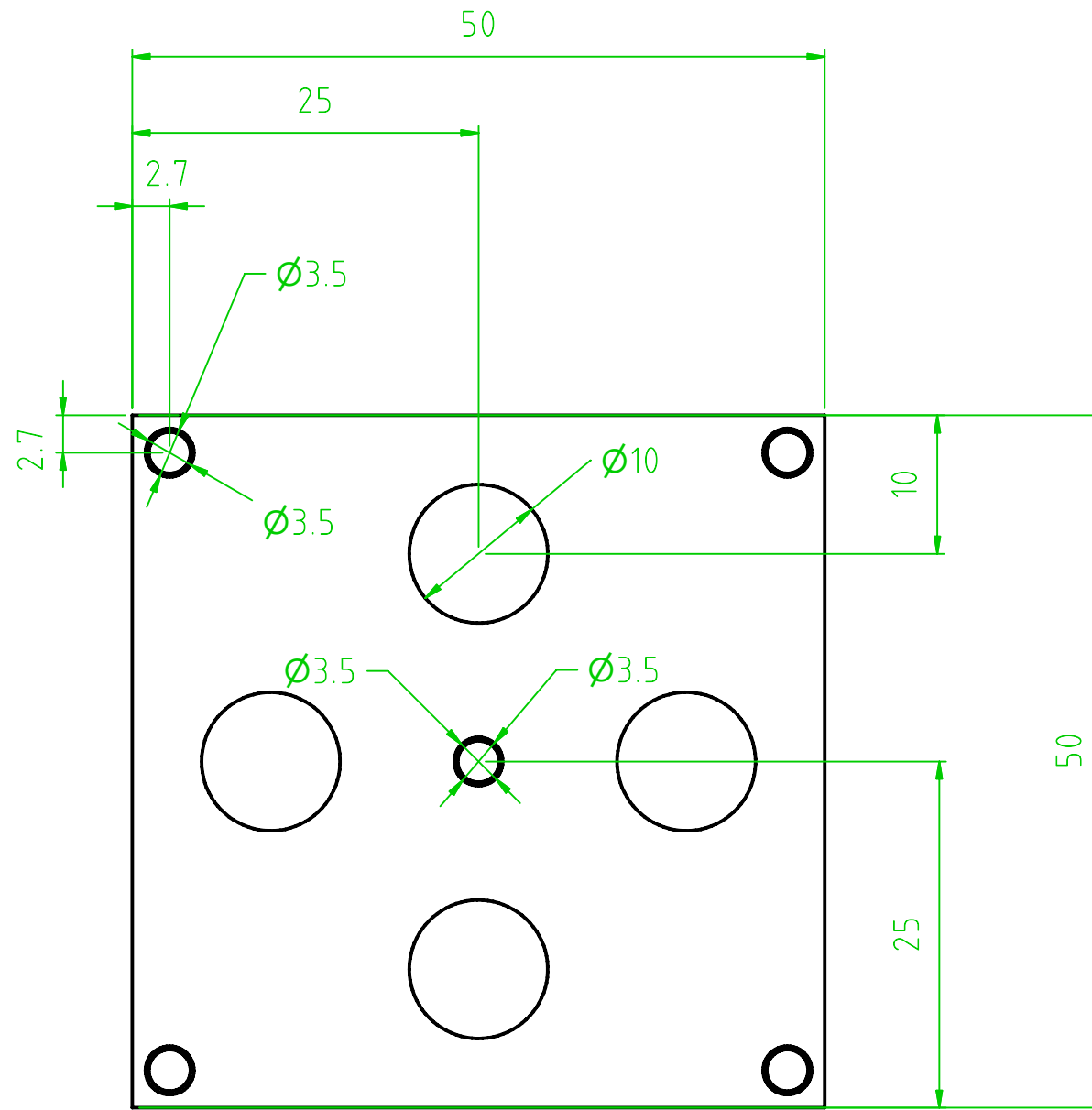
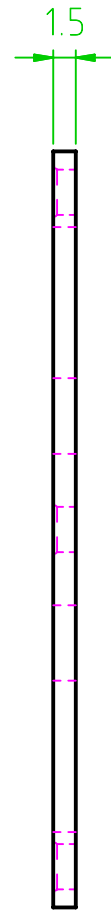
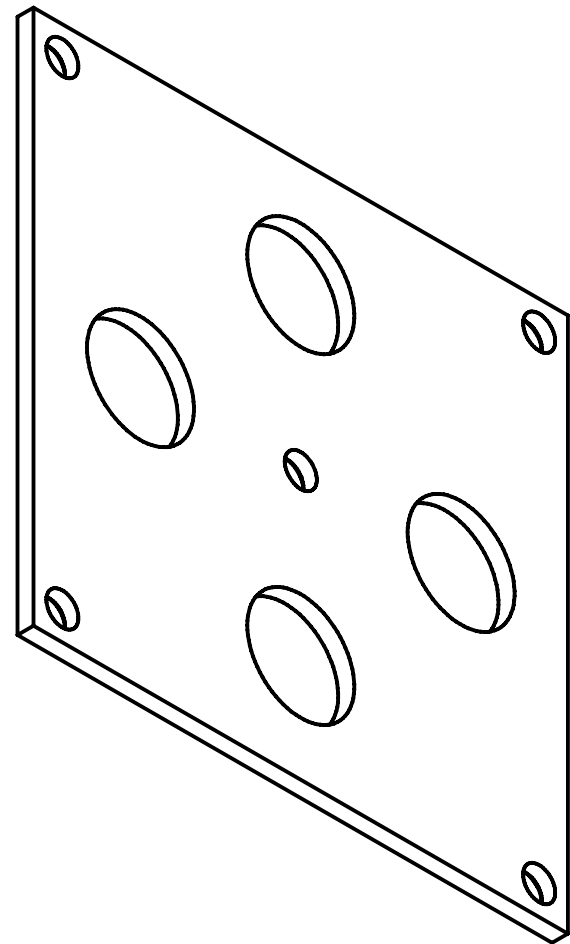

		Surface	Scale 1:2	Position -	Quantity -
			Aluminium	-	-
		Date	Name	www.speedyweb.at www.mikrokoetter.de	
		Drawn 18.06.2007	Speedy		
		Checked			
		Standard			
				Stabilisierungsplatte	
State	Changes	Date	Name	Page -	Pg